

深圳市科飞研科技有限公司

认 可 书

SPECIFICATION FOR APPROVAL

客户名称

CUSTOMER :

客户型号

CLIENT TYPE :

产品编号

PRODUCTION NO.: COG12864C338

出品日期

SHIPMENT DATE: 2016 年 08 月 25 日

客户确认签章:

VALIDATED:

	签名 SIGNATURE	日期 DATE
拟制 PREPARED	王俏	2016.08.25
审核 CHECKED	吴子强	2016.08.25
批准 APPROVED	罗锦炜	2016.08.25

CONTENTS

1	CONTENTS -----	2
2	RECORDS OF REVISION -----	3
3	GENERAL SPECIFICATIONS -----	4
4	FEATURES -----	4
5	MACHANICAL SPECIFICATIONS -----	4
6	OUTLINE DIMENSIONS -----	5
7	ELECTRICAL CHARACTERISTICS -----	6
8	LED BACKLIGT -----	6-7
9	OPTICAL CHARACTERISTICS -----	7
10	DTIMING CHARACTERISTICS -----	8-9
11	PIN ASSIGNMENT -----	10
12	INSTRUCTIONS -----	11
13	ENVIRONMENTAL ABSOLUTE MAXIMUM RATINGS -----	12
14	RELIABILITY -----	12
15	PRECAUTION FOR USE -----	13

RECORDS OF REVISION

STANDARD DOC.	PRODUCT SPEC.	MODULE NO.	COG12864C338	PAGE	4 /16
----------------------	----------------------	-------------------	---------------------	-------------	--------------

Customer.

3-2 PRODUCTS:

Liquid Crystal Display Module (LCM)

3-3 MODULE NAME:

COG12864C338

4. FEATURES :

- (1) Display Type: FSTN, 6 O'CLOCK, Transflective / Positive
- (2) Driving Method: 1/65DUTY, 1/9 BIAS
- (3) Built-in controller: ST7565R
- (4) LED Backlight: 4 PCS White LED Backlight , If=60±5mA & Vf=3.0±0.2V
- (5) VDD: 3.0±0.2V, Vop: 9.0±0.2V

5. MACHANICAL SPECIFICATIONS :

ITEM	SPECIFICATIONS	UNIT
MODULE SIZE	77.4(W)x52.4 (H)x6.5(D)	mm
VIEWING AREA	70.0(W) x 40.0(H)	mm
ACTIVE AREA	66.54 (W) x33.26(H)	mm
DOT SIZE	0.50(W) x0.50(H)	mm
DOT PITCH	0.52(W) x0.52(H)	mm
BACKLIGHT	White	
ASSY.TYPE	COG	---
WEIGHT	TBD	

NOTES:

LCM should be grounded during handling LCM.

6. OUTLINE DIMENSIONS

Characteristic	Symbol	Standard Value			Unit
		MIN	TYP	MAX	
Power Supply Voltage(1)	VDD	2.8	3.0	3.3	V
Power Supply Voltage(2)	LCD	8.8	9.0	9.2	V
Display pattern Current	IDD	0.58		1.4	mA
Input leakage Current	IIL			1.5	uA
Input logic LOW	VIL			0.2VDD	
Input logic HIGH	VIH	0.8VDD			
output logic LOW	VOL			0.2VDD	
output logic HIGH	VOH	0.8VDD			
Operating Temperature	TOPR	-20	—	+70	°C
Storage Temperature	TSTG	-30	—	+80	°C

8. LED BACKLIGHT

8-1 POWER SUPPLY FOR LED BACKLIGHT

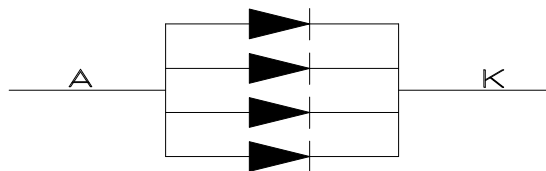

8-2 ELECTRICAL-OPTICAL CHARACTERISTICS

(Ta=25°C .Unless specified,The Ambient temperature Ta=25°C)

Item	Symbol	CONDITIONS	STANDARD VALUE			UNIT
			MIN	TYP	MAX	
Forward Voltage	Vf	If=60mA	2.8	3.0	3.2	V
Forward current	If	Vf=3.0V	55	60	65	mA
Reverse Current	Ir	Vr=3.0V	-	-	100	uA
Spectral Line Half width	$\Delta\lambda$	IF=60mA T=25°C	-	-	-	nm
Peak wave length	λ_p		-	-	-	nm
Chromaticity Coordinates	X					
	Y					
Luminance	Lv	IF=60mA	30		-	Cd/m ²
Uniformity	Δ	MIN/MAX=100%	75	-		%

9 .OPTICAL CHARACTERISTICS

(1) Measuring Instruments For Electro-optical Characteristics

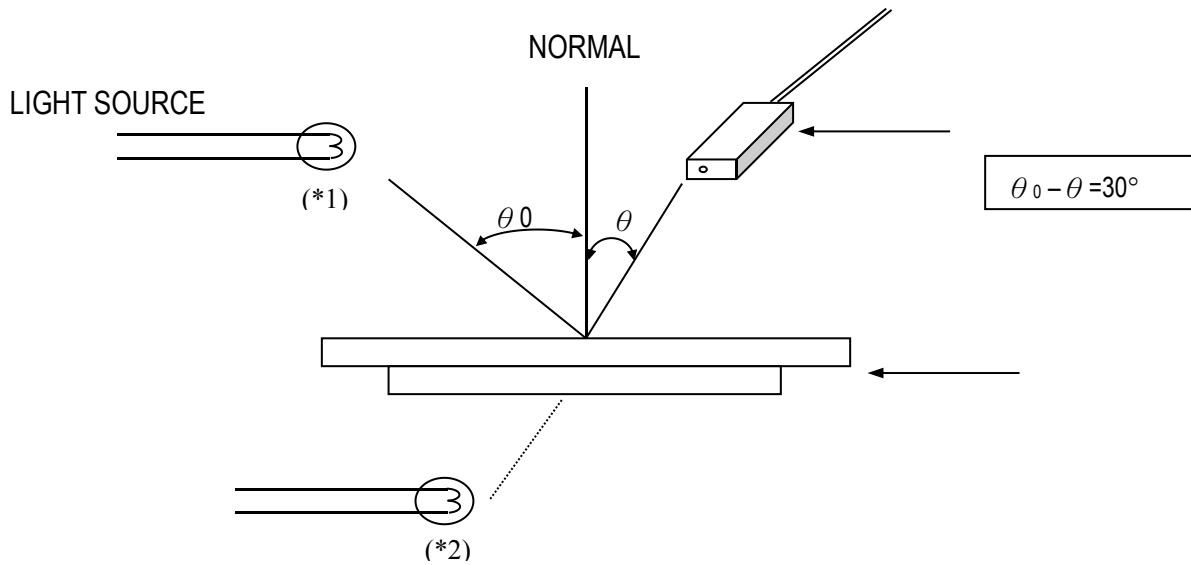

- *1. Light source position for measuring the reflective type of LCD panel
- *2. Light source position for measuring the transfective / transmissive types of LCD panel

10. TIMING CHARACTERISTICS

10.1 Serial Interface

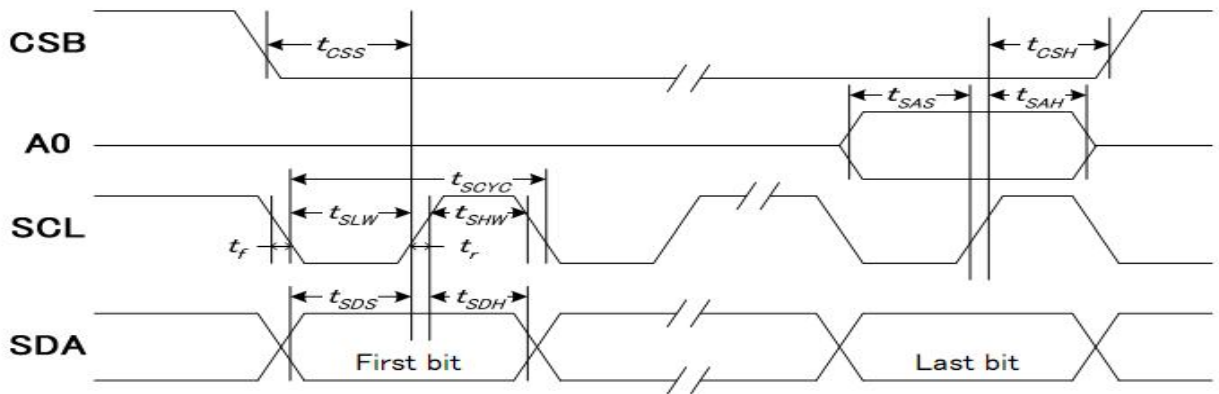

(VDD = 3.3V, Ta = -30~85°C)

Item	Signal	Symbol	Condition	Min.	Max.	Unit
Serial clock period	SCLK	tSCYC		50	—	ns
SCLK "H" pulse width		tSHW		25	—	
SCLK "L" pulse width		tSLW		25	—	
Address setup time	A0	tSAS		20	—	
Address hold time		tSAH		10	—	
Data setup time	SDA	tSDS		20	—	
Data hold time		tSDH		10	—	
CSB-SCLK time	CSB	tCSS		20	—	
CSB-SCLK time		tCSH		40	—	

10.2 6800 Series Interface

System Bus Timing for 6800 Series MPU

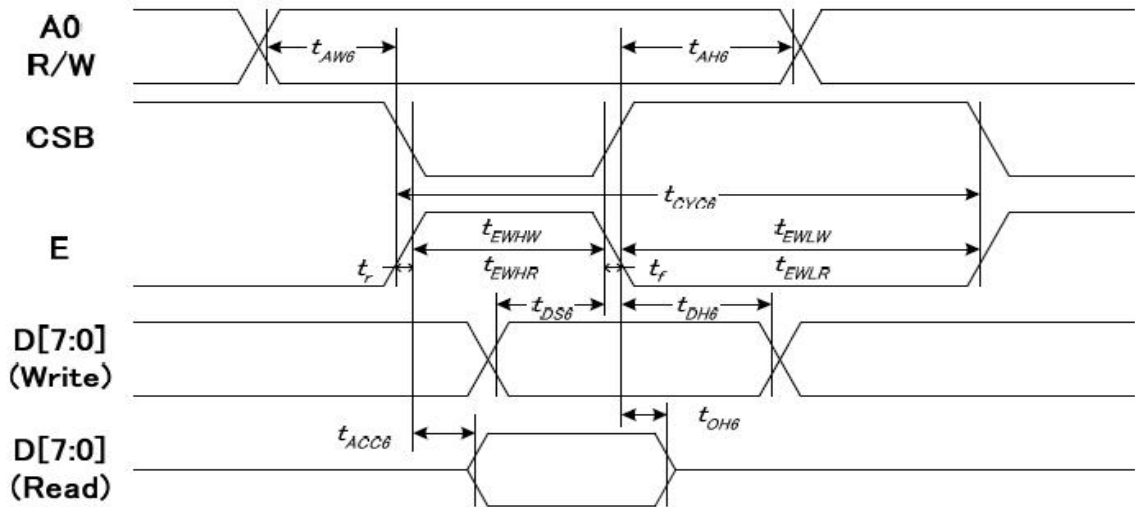

Item	Signal	Symbol	Condition	Rating		Units
				Min.	Max.	
Address hold time	A0	t_{AHB}		0	—	ns
Address setup time		t_{AWB}		0	—	
System cycle time		t_{CYCB}		240	—	
Enable L pulse width (WRITE)	WR	t_{EHLW}		80	—	
Enable H pulse width (WRITE)		t_{EHLR}		80	—	
Enable L pulse width (READ)	RD	t_{EHLW}		80	—	
Enable H pulse width (READ)		t_{EHLR}		140	—	
WRITE Data setup time	D0 to D7	t_{DSB}		40	—	
WRITE Address hold time		t_{DHB}		0	—	
READ access time		t_{ACCB}	CL = 100 pF	—	70	
READ Output disable time		t_{OHB}	CL = 100 pF	5	50	

10.3 8080 Series Interface

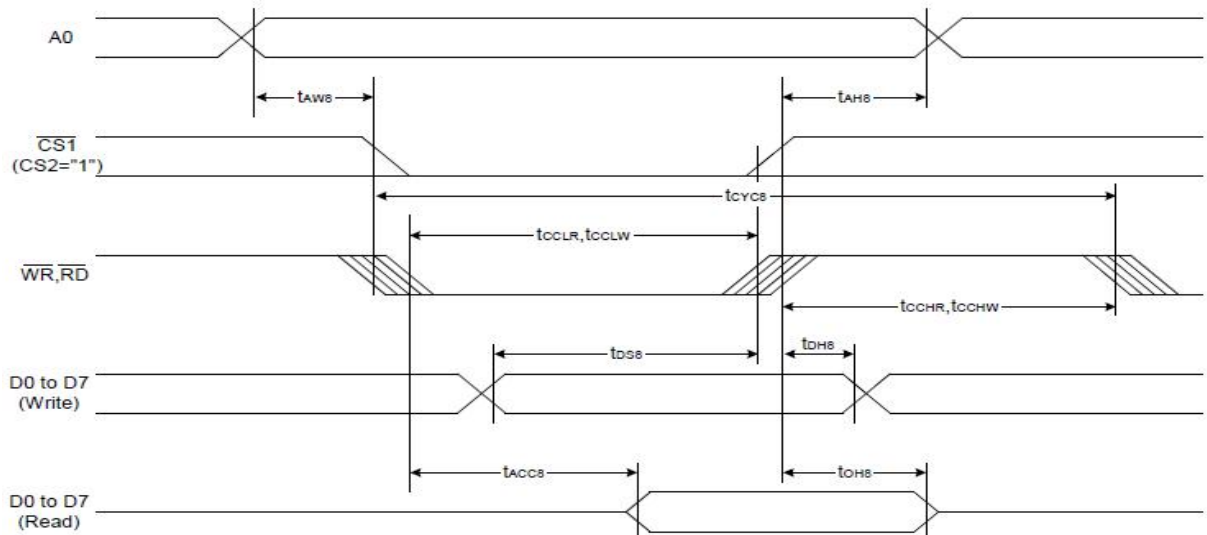

Item	Signal	Symbol	Condition	Rating		Units
				Min.	Max.	
Address hold time	A0	t _{AH8}		0	—	Ns
Address setup time		t _{AW8}		0	—	
System cycle time		t _{CYC8}		240	—	
Enable L pulse width (WRITE)	WR	t _{CCLW}		80	—	
Enable H pulse width (WRITE)		t _{CCHW}		80	—	
Enable L pulse width (READ)	RD	t _{CCLR}		140	—	
Enable H pulse width (READ)		t _{CCHR}		80	—	
WRITE Data setup time	D0 to D7	t _{DS8}		40	—	
WRITE Address hold time		t _{DH8}		0	—	
READ access time		t _{ACC8}	C _L = 100 pF	—	70	
READ Output disable time		t _{OH8}	C _L = 100 pF	5	50	

11. PIN ASSIGNMENT

PIN NO.	FUNCTION DESCRIPTIONS	SYMBOL
1	Chip Select input pin. Active "L"	/CS1
2	Reset input pin. Active "L"	/RES
3	Data or Command select. DATA is "H", COMMAND is "L"	A0
4	Write signal input, active "L"	/WR
5	Read signal input, active "L"	/RD
6-13	8-bit bi-directional data bus.	DB0-DB7
14	POWER	VDD
15	GROUND	VSS
16	DC/DC voltage converter	VOUT
17	DC/DC voltage converter	CAP3+
18	DC/DC voltage converter	CAP1-
19	DC/DC voltage converter	CAP1+
20	DC/DC voltage converter	CAP2+
21	DC/DC voltage converter	CAP2-
22	LCD driving voltage	V4
23	LCD driving voltage	V3
24	LCD driving voltage	V2
25	LCD driving voltage	V1
26	LCD driving voltage	V0
27	Select the MPU system interface mode. 6800 is "H", 8080 is "L"	C86
28	Select the serial or parallel, serial is "L", parallel is "H"	P/S

12.INSTRUCTIONS

INSTRUCTION	A0	R/W (RWR)	COMMAND BYTE								DESCRIPTION
			D7	D6	D5	D4	D3	D2	D1	D0	
(1) Display ON/OFF	0	0	1	0	1	0	1	1	1	D	D=1, display ON D=0, display OFF
(2) Set Start Line	0	0	0	1	S5	S4	S3	S2	S1	S0	Set display start line
(3) Set Page Address	0	0	1	0	1	1	Y3	Y2	Y1	Y0	Set page address
(4) Set Column Address	0	0	0	0	0	1	X7	X6	X5	X4	Set column address (MSB)
	0	0	0	0	0	0	X3	X2	X1	X0	Set column address (LSB)
(5) Read Status	0	1	0	MX	D	RST	0	0	0	0	Read IC Status
(6) Write Data	1	0	D7	D6	D5	D4	D3	D2	D1	D0	Write display data to RAM
(7) Read Data	1	1	D7	D6	D5	D4	D3	D2	D1	D0	Read display data from RAM
(8) SEG Direction	0	0	1	0	1	0	0	0	0	MX	Set scan direction of SEG MX=1, reverse direction MX=0, normal direction
(9) Inverse Display	0	0	1	0	1	0	0	1	1	INV	INV=1, inverse display INV=0, normal display
(10) All Pixel ON	0	0	1	0	1	0	0	1	0	AP	AP=1, set all pixel ON AP=0, normal display
(11) Bias Select	0	0	1	0	1	0	0	0	1	BS	Select bias setting 0=1/9; 1=1/7 (at 1/65 duty)
(12) Read-modify-Write	0	0	1	1	1	0	0	0	0	0	Column address increment: Read:+0, Write:+1
(13) END	0	0	1	1	1	0	1	1	1	0	Exit Read-modify-Write mode
(14) RESET	0	0	1	1	1	0	0	0	1	0	Software reset
(15) COM Direction	0	0	1	1	0	0	MY	-	-	-	Set output direction of COM MY=1, reverse direction MY=0, normal direction
(16) Power Control	0	0	0	0	1	0	1	VB	VR	VF	Control built-in power circuit ON/OFF
(17) Regulation Ratio	0	0	0	0	1	0	0	RR2	RR1	RR0	Select regulation resistor ratio
(18) Set EV	0	0	1	0	0	0	0	0	0	1	Double command!! Set electronic volume (EV) level
	0	0	0	0	EV5	EV4	EV3	EV2	EV1	EV0	
(19) Set Booster	0	0	1	1	1	1	1	0	0	0	Double command!! Set booster level: 00=4X, 01=5X, 10=6X
	0	0	0	0	0	0	0	0	BL1	BL0	
(20) Power Save	0	0	Compound Command								Display OFF + All Pixel ON
(21) NOP	0	0	1	1	1	0	0	0	1	1	No operation
(22) Test	0	0	1	1	1	1	1	1	1	-	Do NOT use. Reserved for testing.

Note: Symbol "-" means this bit can be "H" or "L".

13. ENVIRONMENTAL ABSOLUTE MAXIMUM RATINGS

ITEM	SYMBOL	CONDITIONS	CRITERION
OPERATING TEMPERATURE	TOPR	-20°C ~ +70°C	NO DEFECT IN DISPLAYING AND OPERATIONAL FUNCTION
STORAGE TEMPERATURE	TSTG	-30°C ~ +80°C	NO DEFECT IN DISPLAYING AND OPERATIONAL FUNCTION

14.RELIABILITY

STANDARD DOC.	PRODUCT SPEC.	MODULE NO.	COG12864C338	PAGE	11 /16
----------------------	----------------------	-------------------	---------------------	-------------	---------------

ITEM	CONDITIONS	CRITERION
OPERATING TEMPERATURE	HIGH TEMPERATURE +70°C 96HRS	NO DEFECT IN DISPLAYING AND OPERATIONAL FUNCTION
	LOW TEMPERATURE -20°C 96HRS	
STORAGE TEMPERATURE	HIGH TEMPERATURE +80°C 96HRS	NO DEFECT IN DISPLAYING AND OPERATIONAL FUNCTION
	LOW TEMPERATURE - 30°C 96HRS	
HUMIDITY	40°C 90%RH 96HRS	NO DEFECT IN DISPLAYING AND OPERATIONAL FUNCTION
VIBRATION	<ul style="list-style-type: none"> • Operating Time: thirty minutes exposure for each direction (X,Y,Z) • Sweep Frequency: 10~55Hz (1 min) • Amplitude: 1.5mm 	NO DEFECT IN DISPLAYING AND OPERATIONAL FUNCTION
THERMAL SHOCK	-20°C (30mins) ←→+70°C (30mins) 10 cycles	NO DEFECT IN DISPLAYING AND OPERATIONAL FUNCTION

***NOTE: TEST CONDITION**

(1)TEMPERATURE AND HUMIDITY: IF NO SPECIFICATION, TEMP. SET AT 25±2°C, HUMIDITY SET AT 60±5%RH

(2) OPERATING STATE: SAMPLES SUBJECT TO THE TESTS SHALL BE IN " OPERATING" CONDITION

15. Precaution for Use

The following precautions should be followed, since this module contains precise parts.

- (1) Do not store module for an extended periods of time under the conditions of high temperature and high humidity.
- (2) Avoid using or storing the module in areas that expose it to direct sunlight or ultraviolet rays.
- (3) Use protective finger covers when handling the module to avoid scratching or staining the module.
- (4) Care should be taken not to expose the module to static electricity, because the module contains C-MOS LSI's.
- (5) The LSI is sensitive to light.
The user's product should be designed so that LSI is not exposed to any light during operation.
- (6) During installation, cover the display area with acrylic protection plates to protect the polarizer plate and LCD cells.
- (7) Do not apply any excessive shocks to the module because the module contains sensitive LCD cells.
Do not use a module, which has experienced strong mechanical shock.
- (8) Care should be taken when the power supply turns on as following.
 - (a) Do not apply any input signals before the supplying voltage is applied.
 - (b) Do not turn off the power supply while any input signals are applied.

Caution

- (1) Dangerous. Do not shock glass because glass can break.

STANDARD DOC.	PRODUCT SPEC.	MODULE NO.	COG12864C338	PAGE	12 /16
------------------	------------------	---------------	--------------	------	--------

- (2) If module breaks, do not touch it directly.
(Glass could stick or cut skin.)
- (3) Do not swallow Liquid Crystal.
(In case of broken LCD panel, do not swallow liquid crystal even if there is no proof that liquid crystal is poisonous.)
- (4) If liquid crystal is exposed to skin, wash the area thoroughly with alcohol or soap.
- (5) When disposing of the product, please observe industrial waste disposal laws in each country and district.
- (6) In case of injury, give immediate treatment and consult with a doctor.
- (7) This product is constructed precisely. Don't disassemble or modify.

※ Neglecting this mark can cause injury to humans and damage to materials