

SPECIFICATION FOR APPROVAL



Product Type: Graphic Type STN Dot Matrix
LCD Module

Part No.: G19264C

Customer: _____

Customer Part No.: _____

Date: _____

APPOVED SIGNATURES

K F Y	Customer

KE FEI YAN DISPLAY CO.,LTD

- 1 . REVISION RECORD
2. GENERAL SPECIFICATION
3. OUTLINE DEMENSION:
4. BLOCK DIAGRAM
- 5.ABSOLUTE MAXIMUM RATINGS
- 6.ELECTRICAL CHARACTERISTICS
- 7.ABSOLUTE MAXIMUM RATINGS FOR LED BACKLIGHT
- 8.PIN ASSIGNMENT
- 9.MPU INTERFACE
- 10.REFLECTOR OF SCREEN AND DIPLAY RAM
- 11.DISPLAY CONTROL INSTRUCTION
- 12.OPTICAL CHARACTERISTICS
- 13.POWER SUPPLY SCHEMATICS
- 14.APPLICATION EXAMPLE
15. PRECAUTION FOR USING LCM

1. REVISION RECORD

REV	DATA	PAGES	DESCRIPTION

2. GENERAL SPECIFICATION

192×64 dots display

SAM SUNG LCD driver:KS0107B and KS0108B

Interface with 8-bit MPU (directly connected to M6800serial MPU)

Display specification

Display dot: 192×64

Display type: STN

Display color-Display background color: Black-YELLOW

Polarizer mode: positive; Transflective

Viewing angle:6:00

Display RAM:12288 bits

Mechanical characteristics (Unit: mm)

External dimension: 100X60X12.5

View area: 84X31

Dot size: 0.36X0.36

Dot pitch: 0.41X0.41

Weight: 100g

POWER: +5V

3.OUTLINE DEMENSION:

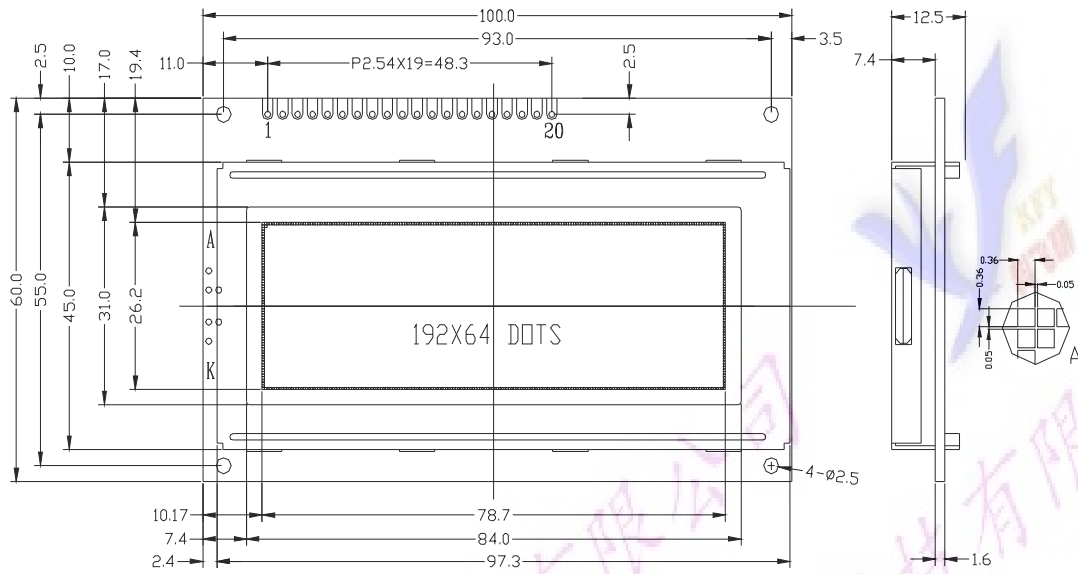

4.BLOCK DIAGRAM:

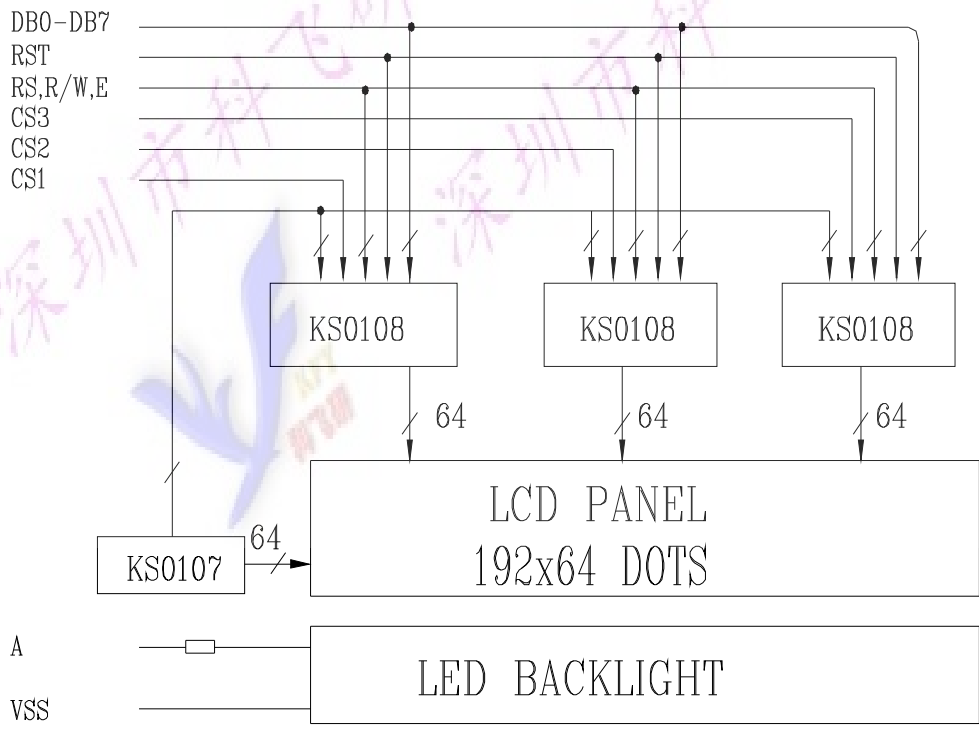

5. Absolute Maximum Ratings

Item	Symbol	Condition	Standard Value		Unit
			Min	Max	
Supply voltage for logic	Vdd	Ta=25°C	-0.3	7.0	V
Supply voltage for LCD	Vo		Vdd-10.0	Vdd+0.3	V
Input Voltage	Vi		-0.3	Vdd+0.3	V
Operating Temp(T)	Top	-	-20	70	°C
Storage Temp(T)	Tstg	-	-30	80	°C

6. ELECTRICAL SPECIFICATIONS(Ta=25°C,Vdd=5.0V)

Item	Symbol	Condition	Standard Value			Unit
			Min	Type	Max	
Supply voltage for logic	Vdd-Vss	-	4.5	5.0	5.5	V
Supply Current for logic	Idd	Vdd=5.0	-	5.0	-	mA
Driving Current for LCD	Iee	Vee=-7.8	-	4.0	-	mA
Driving Voltage for LCD	Vo	25°C -	-	12.0	-	V
Input Voltage "H" level	Tih1	H	0.7Vdd	-	Vdd	V
Input Voltage "L" level	Til2	L	0	-	0.3Vdd	V

7. Absolute Maximum Ratings For Side LED Backlight

Parameter	Symbol	Test condition	Min	Type	Max	Unit
LED Forward Consumption Current	I _f	Ta=25°C	-	130	200	mA
LED Allowable Dissipation	P _d	Vf=5.0V	-	520	840	mW

8. Pin assignment

Pin NO.	Symbol	Function	Remark
1~8	DB7-DB0	Data Bit 7~0	
9	E	Enable signal for LCM	
10	R/W	Read/Write selection	Variable
11	RS	Register Select (H: Data L: Instruction)	
12	V0	Power supply for LCD driver	
13	VDD	Power supply for logic	
14	VSS	Ground for logic	
15	CSA	Chip Select Signal	
16	CSB	Chip Select Signal	
17	Vout	Negative Power Supply output	
18	/RST	RESET	
19	BL+	LED BL(+5.0V)	
20	BL-	LED BL -	

9. MPU Interface

Characteristic	Symbol	Min	Type	Max	Unit
E Cycle	Tc	1000	-	-	ns
E High Level Width	Twh	450	-	-	ns
E Low Level Width	Twl	450	-	-	ns
E Rise Time	Tr	-	-	25	ns
E Fall Time	Tf	-	-	25	ns
Address Ste-Up Time	Tasu	140	-	-	ns
Address Hold Time	Tah	10	-	-	ns
Data Set-Up Time	Tdsu	200	-	-	ns
Data Delay Time	Td	-	-	320	ns
Data Hold Time(Write)	Tdhw	10	-	-	ns
Data Hold Time(Read)	tdhr	20	-	-	ns

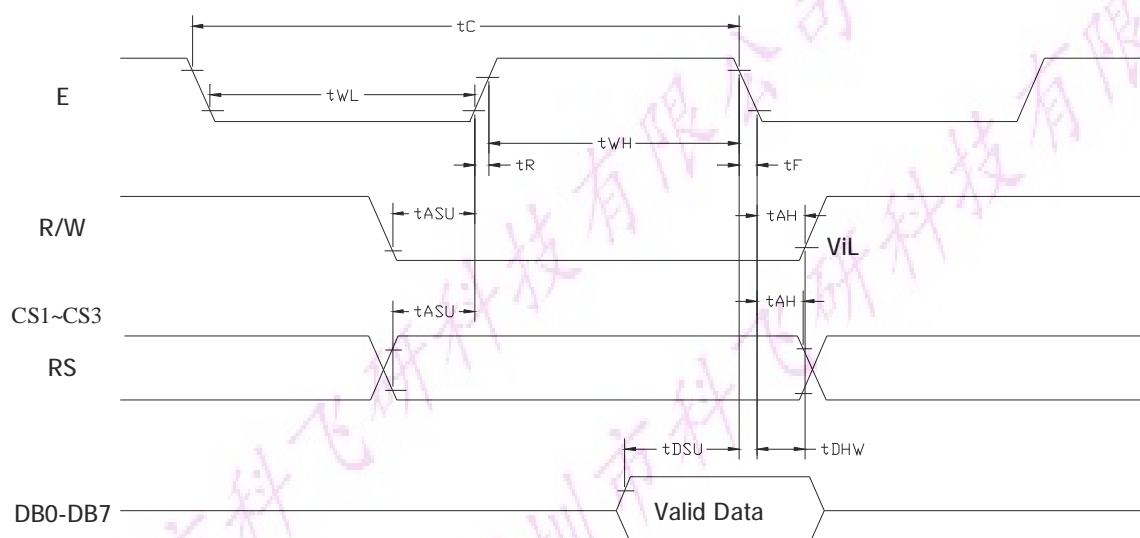

MPU writing timing

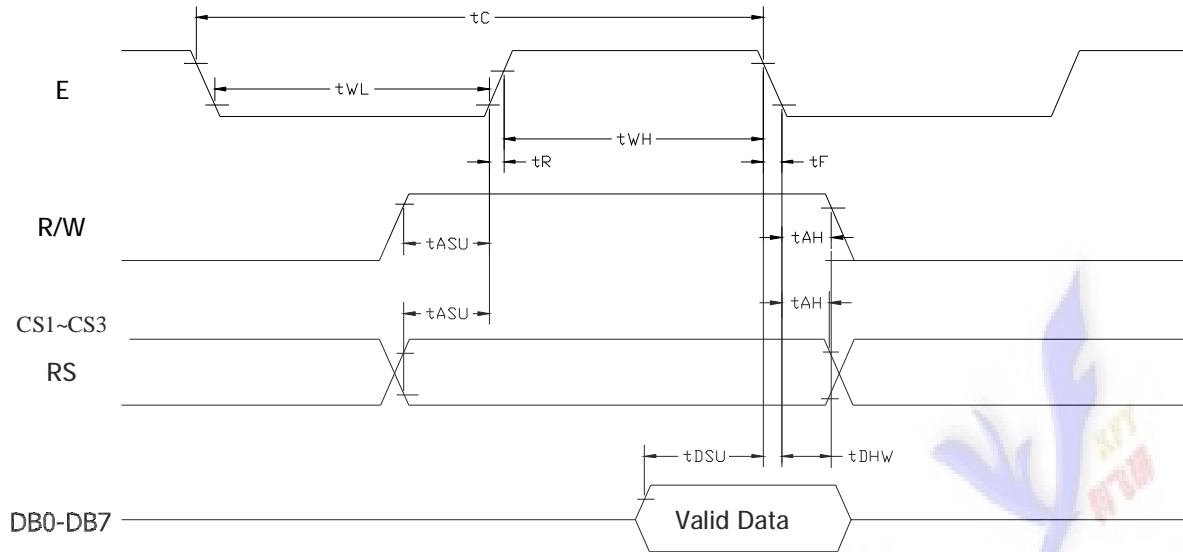

MPU read timing

10. Reflector of Screen and Display RAM

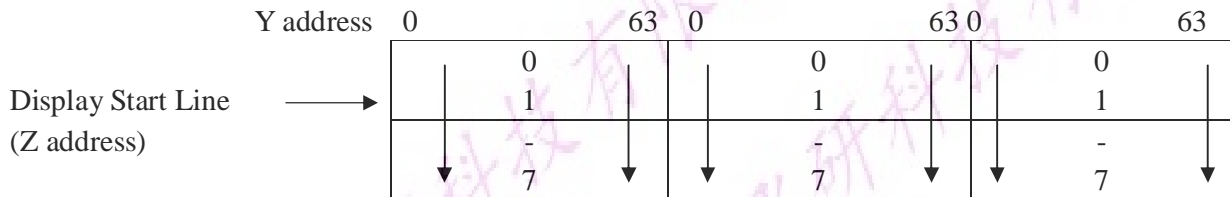

Correspondence with data bits and arrow direction



11. DISPLAY CONTROL INSTRUCTION

Instruction	RS	R/W	DB7	DB6	DB5	DB4	DB3	DB2	DB1	DB0	Function
Display ON/OFF	L	L	L	L	H	H	H	H	H	L/H	Controls the display on or off. Internal status and display RAM data is not affected. L:OFF, H:ON
Set address (Y address)	L	L	L	H	Y address(0~63)					Sets the Y address in the Y address counter	

Set page (X address)	L	L	H	L	H	H	H	Page(0~7)			Sets the Y address at the X address register.
Display Start Line (Z address)	L	L	H	H	Display start line(0~63)						Indicates the display data RAM displayed at the top of the screen.
Status Read	L	H	B U S Y	L	O N / O F F	R E S E T	L	L	L	L	BUSY L: Ready H: In operation ON/OFF L: Display OFF RESET L: Normal H: Reset
Write Display Data	H	L	Write Data								Writes data (DB0:7) into Display data RAM, After writing instruction, Y address is increased by 1 automatically.
Read Display Data	H	H	Read Data								Reads data (DB0:7) from display data RAM to the data bus.

1. Display On/Off

RS	R/W	DB7	DB6	DB5	DB4	DB3	DB2	DB1	DB0
0	0	0	0	0	0	0	0	0	0

The display data appears when D is 1 and disappears when D is 0.

Though the data is not in the screen with D=0, it remains in the display data RAM.

Therefore, you can make it appear by changing D=0 into D=1.

2. Set Address(Y Address)

RS	R/W	DB7	DB6	DB5	DB4	DB3	DB2	DB1	DB0
0	0	0	1	AC5	AC4	AC3	AC2	AC1	AC0

Y address (AC0-AC5) of the display data RAM is set in the Y address counter.

An address is set by instruction and increased by 1 automatically by read or write operations of display data.

3. Set Page(X Address)

RS	R/W	DB7	DB6	DB5	DB4	DB3	DB2	DB1	DB0
0	0	1	0	1	1	1	AC2	AC1	AC0

X address (AC0-AC2) of the display data RAM is set in the X address register,

Writing or reading to or from MPU is executed in this specified page until next page is set.

4. Display Start Line (Z Address)

RS	R/W	DB7	DB6	DB5	DB4	DB3	DB2	DB1	DB0
0	0	1	1	AC5	AC4	AC3	AC2	AC1	AC0

Z address (AC0-AC5) of the display data RAM is set in the display start line register and displayed at the top of the screen.

When the display duty cycle is 1/64 or others (1/32-1/64), the data of total line number of LCD screen, from the line specified by display start line instruction, is displayed.

5. Status Read

RS	R/W	DB7	DB6	DB5	DB4	DB3	DB2	DB1	DB0
1	0	BUSY	0	ON/OFF	RESET	0	0	0	0

I BUSY

When BUSY is 1, the Chip is executing internal operation and no instructions are accepted.

When BUSY is 0, the Chip is ready to accept any instructions.

I ON/OFF

When ON/OFF is 1, the display is on.

When ON/OFF is 0, the display is off.

I RESET

When RESET is 1, the system is being initialized.

In this condition, no instructions except status can be accepted.

When RESET is 0, initializing has finished and the system is in the usual operation condition.

6. Write Display Data

RS	R/W	DB7	DB6	DB5	DB4	DB3	DB2	DB1	DB0
0	1	D7	D6	D5	D4	D3	D2	D1	D0

Writes data (D0-D7) into the display data RAM.

After writing instruction, Y address is increased by 1 automatically.

7. Read Display Data

RS	R/W	DB7	DB6	DB5	DB4	DB3	DB2	DB1	DB0
1	1	D7	D6	D5	D4	D3	D2	D1	D0

Reads data (D0-D7) from the display data RAM.

After reading instruction, Y address is increased by 1 automatically.

12. OPTICAL CHARACTERISTICS:

ITEM	SYMBOL	CONDITION	MIN.	TYP.	MAX.	UNIT	REF.
Contrast	CR	25 °C, Vdd=5V, $\theta = 0, \phi = 0$	--	12	--		(2)
Rise Time	T_r	25 °C, Vdd=5V, $\theta = 0, \phi = 0$	--	160	240	ms	(3)
Fall Time	T_f	25 °C, Vdd=5V, $\theta = 0, \phi = 0$	--	100	150	ms	(3)
Viewing Angle	$\theta 1 - \theta 2$	25 °C	--	--	60	DEG	(1)
	$\phi 1, \phi 2$		-40	--	40		

(1) Definition of viewing Angle:

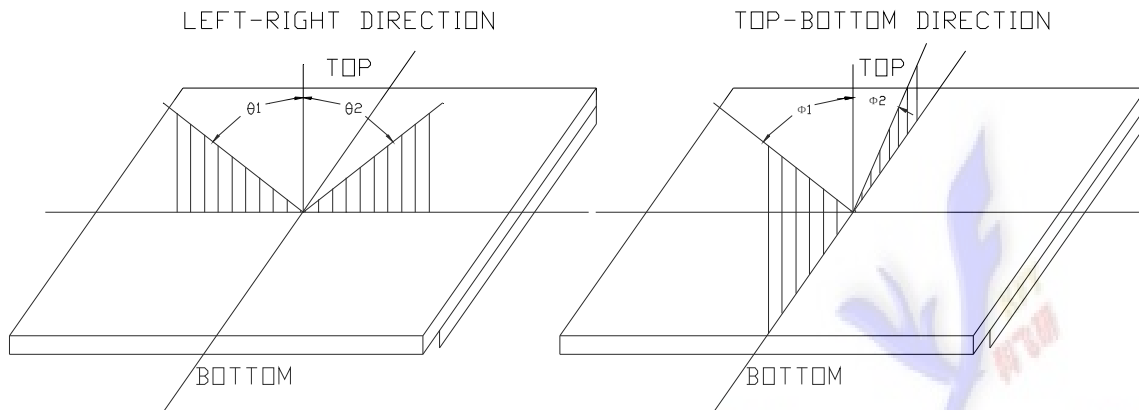

(2) Definition of Contrast Ratio:

$$\text{Contrast Ratio} = \frac{\text{Brightness of non-selected condition}}{\text{Brightness of selected condition}}$$

Test condition: standard A light source

(3) Response Time:

Response time is measured as the shortest period of possible between the change in state of an LCD segments as demonstrated below:

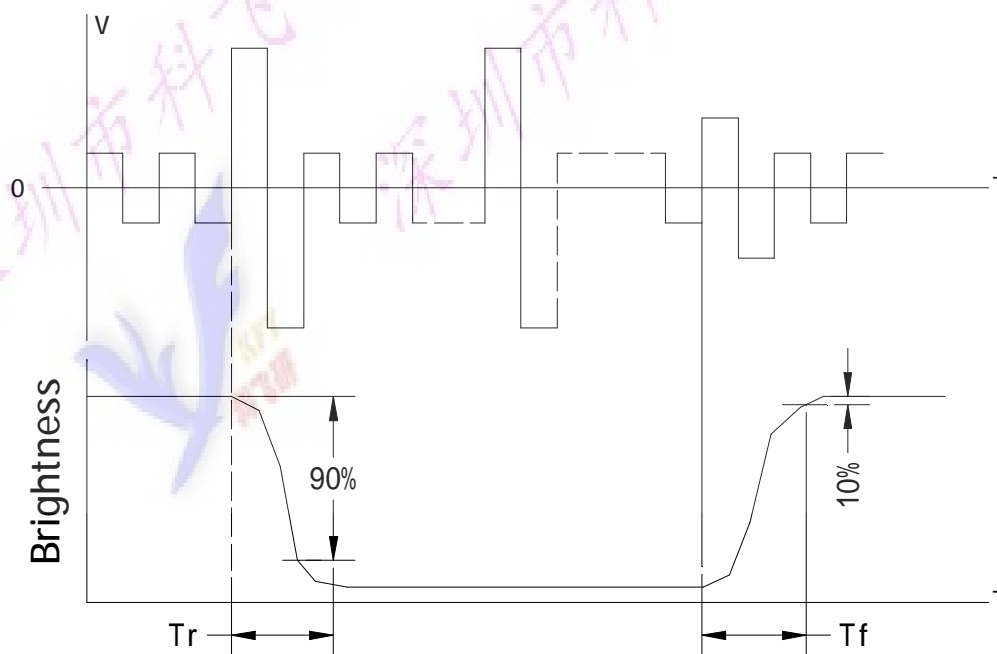

13. POWER SUPPLY SCHEMATICS

For Single Source

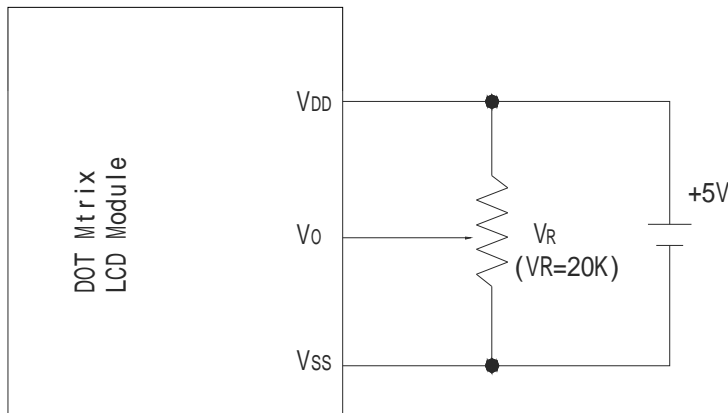

For Double Source

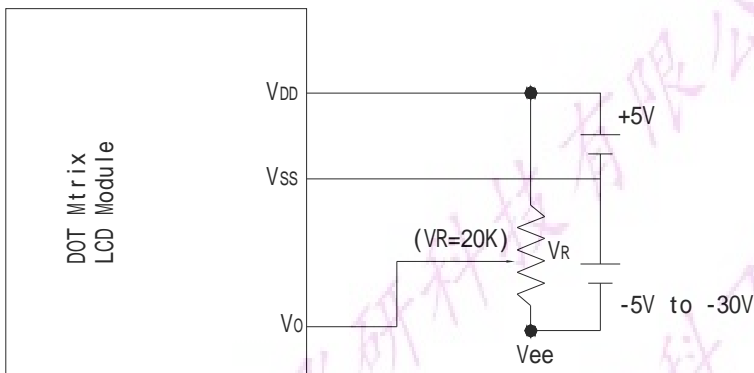

14. APPLICATION EXAMPLE

Application Circuit

M	E	P3.0	8
L	R/W	P3.1	
C D	RS	P3.2	0
D U	DB0~DB7	P1.0~P1.7	
L	Vdd	Vdd	1
E	Vss	Vss	
		12	
			(6M Hz)

Application Flowchart

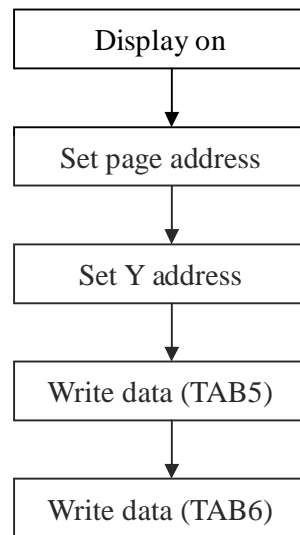

15. PRECAUTION FOR USING LCM

1. LIQUID CRYSTAL DISPLAY (LCD)

LCD is made up of glass, organic sealant, organic fluid, and polymer based polarizers. The following precautions should be taken when handling,

- (1). Keep the temperature within range of use and storage. Excessive temperature and humidity could cause polarization degradation, polarizer peel off or bubble.
- (2). Do not contact the exposed polarizers with anything harder than an HB pencil lead. To clean dust off the display surface. Wipe gently with cotton. Chamois or other soft material soaked in petroleum benzine.
- (3). Wipe off saliva or water drops immediately. Contact with water over a long period of time may cause polarizer deformation or color fading, while an active LCD with water condensation on its surface will cause corrosion of ITO electrodes.
- (4). Glass can be easily chipped or cracked from rough handling. especially at corners and edges.
- (5). Do not drive LCD with DC voltage.

2. Liquid Crystal Display Modules

2.1 Mechanical Considerations

LCM are assembled and adjusted with a high degree of precision. Avoid excessive shocks and do not make any alterations or modifications. The following should be noted.

- (1). Do not tamper in any way with the tabs on the metal frame.
- (2). Do not modify the PCB by drilling extra holes, changing its outline, moving its components or modifying its pattern.
- (3). Do not touch the elastomer connector, especially insert an backlight panel (for example, EL).
- (4). When mounting a LCM make sure that the PCB is not under any stress such as bending or twisting. Elastomer contacts are very delicate and missing pixels could result from slight dislocation of any of the elements.
- (5). Avoid pressing on the metal bezel, otherwise the elastomer connector could be deformed and lose contact, resulting in missing pixels.

2.2. Static Electricity

LCM contains CMOS LSI's and the same precaution for such devices should apply, namely

- (1). The operator should be grounded whenever he/she comes into contact with the module. Never touch any of the conductive parts such as the LSI pads, the copper leads on the PCB and the interface terminals with any parts of the human body.
- (2). The modules should be kept in antistatic bags or other containers resistant to static for storage.
- (3). Only properly grounded soldering irons should be used.
- (4). If an electric screwdriver is used, it should be well grounded and shielded from commutator sparks.
- (5). The normal static prevention measures should be observed for work clothes and working benches; for the latter conductive (rubber) mat is recommended.
- (6). Since dry air is inductive to static, a relative humidity of 50-60% is recommended.

2.3. Soldering

- (1). Solder only to the I/O terminals.
- (2). Use only soldering irons with proper grounding and no leakage.
- (3). Soldering temperature: $280\text{ }^{\circ}\text{C} \pm 10^{\circ}\text{C}$
- (4). Soldering time: 3 to 4 sec.
- (5). Use eutectic solder with resin flux fill.
- (6). If flux is used, the LCD surface should be covered to avoid flux spatters. Flux residue should be removed after wards.

2.4. Operation

- (1). The viewing angle can be adjusted by varying the LCD driving voltage V_0 .
- (2). Driving voltage should be kept within specified range; excess voltage shortens display life.
- (3). Response time increases with decrease in temperature.
- (4). Display may turn black or dark blue at temperatures above its operational range; this is (however not pressing on the viewing area) may cause the segments to appear "fractured".
- (5). Mechanical disturbance during operation (such as pressing on the viewing area) may cause the segments to appear "fractured".

2.5. Storage

If any fluid leaks out of a damaged glass cell, wash off any human part that comes into contact with soap and water. Never swallow the fluid. The toxicity is extremely low but caution should be exercised at all the time.