

**DOT MATRIX
LIQUID CRYSTAL DISPLAY
MODULE**

USER' MANUAL

MODEL: G19264E

PROPOSED BY		APPROVED
Design	Approved	

CONTENTS

	PAGE
1. Mechanical Specification	2
2 Mechanical Diagram	2
3. Interface Pin Connections	2
4. Block And Power Supper Diagram	2
5. Electrical Absolute Maximum Ratings	3
6. Environmental Absolute Maximum Ratings	3
7. Electrical Characteristics	3
8. Electro-Optical Characteristics	3
9. Timing Control	3
10. Instruction Set	4
11. Description Of Instructions	4
12. Initializing And Programming	5
13. Reliability Condition	6
14. Functional Test & Inspection Criteria	6

1. Mechanical Specification

ITEM	STANDARD VALUE			UNIT
DOT MATRIX FORMAT	192 X 64 DOTS			--
MODULE DIMENSION	140.0 (W) X 53.0 (H) X12.5 (T)			mm
VIEWING DISPLAY AREA	104.0 (W) X 39.0 (H)			mm
ACTIVE DISPLAY AREA	95.95 (W) X 31.95 (H)			mm
DOT SIZE	0.45 (W) X 0.45 (H)			mm
DOT PITCH	0.5 (W) X 0.5 (H)			mm
APPROX. WEIGHT	—			g
LCD TYPE	STN , BULER, 1/64 DUTY , 1/9 BIAS , 6 O'clock			
BACKLIGHT TYPE	LED	USE INVERTER		
BACKLIGHT INPUT	DC +3.30 V	V	120	mA
BACKLIGHT Half-Lift TIME	50,000			HR.

2. Mechanical Diagram

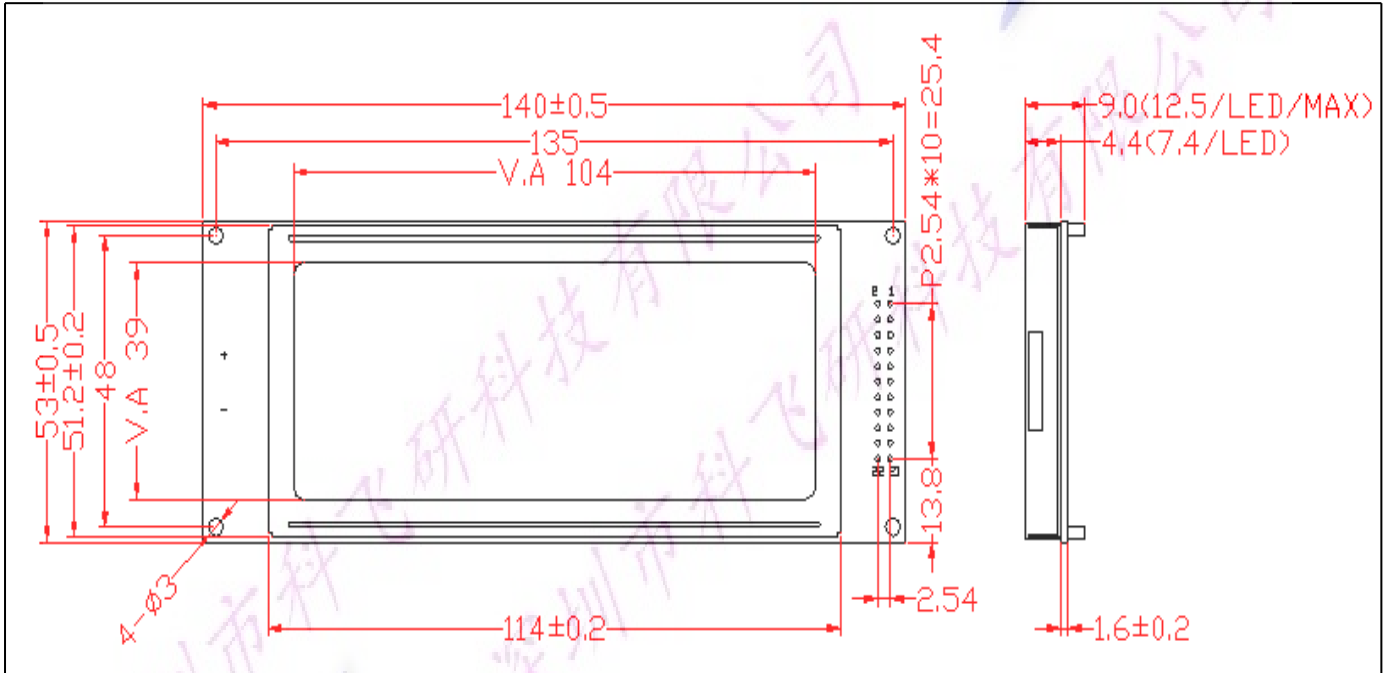

3. Interface Pin Connections

NO	SYMBOL	LEVEL	FUNCTION
1	VSS	--	GND (0V)
2	VCC	--	DC +3.30 V
3	VO	--	Contrast Adjust
4	VEE	DC -10V	Negative voltage output
5	RS	H/L	Data / Instruction code
6	R/W	H/L	Read / Write
7	E	H,H→L	Enable signal
8	DB0	H/L	Data Bit 0
9	DB1	H/L	Data Bit 1
10	DB2	H/L	Data Bit 2
11	DB3	H/L	Data Bit 3
12	DB4	H/L	Data Bit 4
13	DB5	H/L	Data Bit 5
14	DB6	H/L	Data Bit 6
15	DB7	H/L	Data Bit 7
16	/CS1	L	Chip 1 enable signal
17	/CS2	L	Chip 2 enable signal
18	/CS3	L	Chip 3 enable signal
19	/RST	L	Reset signal
20	LED(+)	+3.30 V	LED backlight +
21	LED(-)	0V	LED backlight -

4. Black And Power Supply Diagram

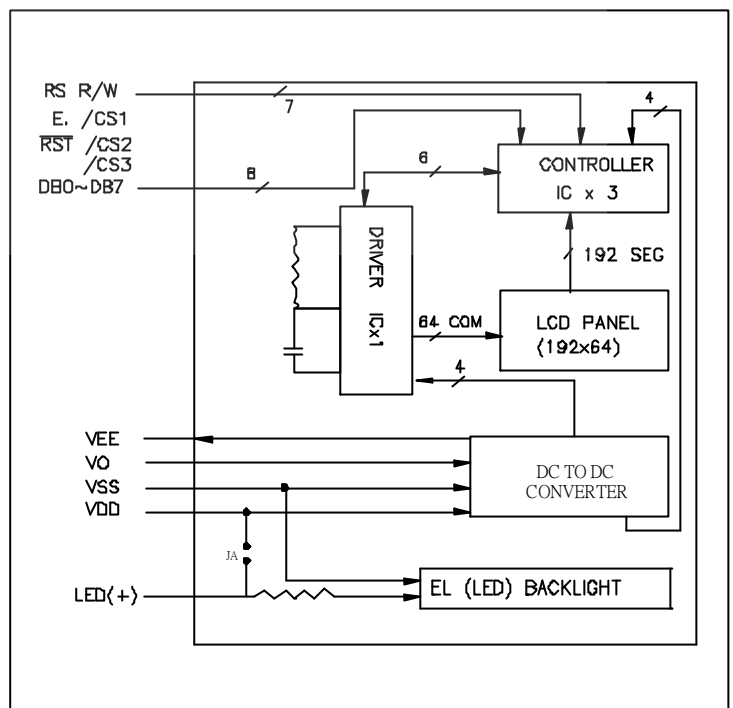

5. Electrical Absolute Maximum Ratings

ITEM	SYMBOL	MIN.	TYPE	MAX.	UNIT
SUPPLY VOLTAGE FOR LOGIC	VDD-VSS	--	3.30	5.50	V
SUPPLY VOLTAGE FOR LCD	VDD-VEE	--	--	9.90	V
INPUT VOLTAGE	VI	VSS	--	VDD	V

6. Environmental absolute maximum ratings

ITEM	OPERATING		STORAGE		REMARKS
	MIN.	MAX.	MIN.	MAX.	
Ambient Temperature	-20 °C	70 °C	-30 °C	80 °C	NOTE 1
Humidity	NOTE 1		NOTE 2		Without Condensation
Vibration	--	4.9m/s ²	--	19.6m/s ²	XYZ Directions
Shock	--	29.4m/s ²	--	490.0m/s ²	XYZ Directions

Remarks:

NOTE (1) : Ta at 60 °C : 50 HR Max.

NOTE (2) : Ta < 40 °C : 95% RH Max.

Ta > 40 °C : Absolute humidity must be lower than the humidity of 95% at 40 °C.

7. Electrical Characteristics

ITEM	SYN	CONDITION	MIN.	TYPE	MAX.	UNIT
SUPPLY VOLTAGE FOR LOGIC	VDD-VSS	--	2.7	3.3	5.5	V
SUPPLY VOLTAGE FOR LCD	VDD-VEE	Ta= 25 °C	3.3	--	9.90	V
INPUT HIGH VOLTAGE	VIH	NOTE 1	0.7VDD	--	VDD	V
INPUT LOW VOLTAGE	VIL	NOTE 1	0	--	0.3VDD	V
SUPPLY CURRENT (LOGIC)	IDD	VDD=+3.30V,VEE=-6.6V	--	--	4.0	mA
SUPPLY CURRENT (LCD)	ILCD	VDD=+3.30V,VEE=-6.6V	--	--	3.0	mA

NOTE (1) : CS1,CS2,R/W,D/L,DB0~7,E, and RST.

8. Electro-Optical Characteristics

ITEM	SYM	TEMP (°C)	MIN.	TYPE	MAX.	UNIT
RESPONSE TIME	tr	0	--	2450	--	ms
	tr	25	--	384	--	ms
	tf	0	--	2088	--	ms
	tf	25	--	98	--	ms
FRAME FREQUENCY	ff	--	--	--	--	Hz
OPERATING VOLTAGE	Vop	0	12.3	13.0	13.7	V
		25	11.0	11.7	12.4	V
		50	10.2	10.9	11.6	V
VIEWING ANGLE	F-B	Ai	--	55	--	deg
	R-L	Qi	--	60	--	deg
CONTRAST RATIO	K	25	--	22.8	--	--

9. Timing Control

Write Operation (NOTE 1)

Read Operation (NOTE 2)

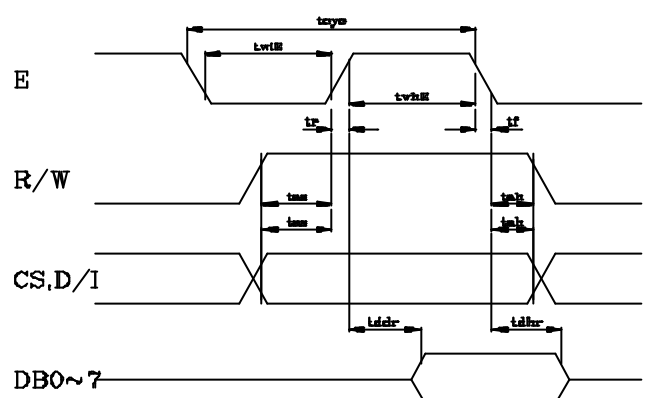
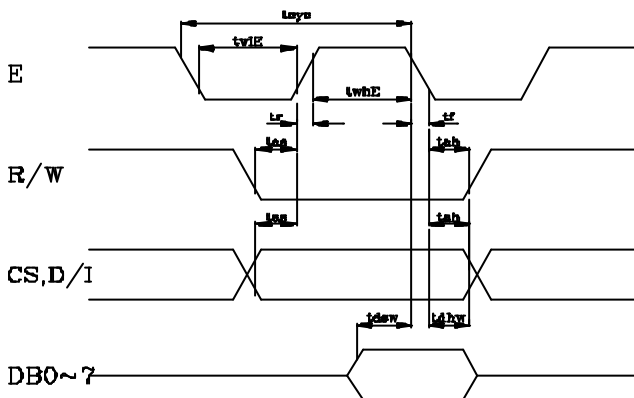

Item	Symbol	Limit (Min.)	Limit (Max.)	Unit
E cycle	teyc	1000	--	ns
E high level width	twhE	450	--	ns
E low level width	twlE	450	--	ns
E rise time	tr	--	25	ns
E fall time	tf	--	25	ns
Address set-up time	tas	140	--	ns
Address hold time	tah	10	--	ns
Data set-up time	tdsw	200	--	ns
Data delay time	tddr	--	320	ns
Data hold time (write)	tdhw	10	--	ns
Data hold time (read)	tdhr	20	--	ns

10. Instruction Set

FUNCTION	R/W	D/I	DB7	DB6	DB5	DB4	DB3	DB2	DB1	DB0	FUNCTION
1. Display ON/OFF	0	0	0	0	1	1	1	1	1	1/0	Controls the ON/OFF of the display. RAM data internal status are not affected. 1:ON, 0:OFF.
2. Display start line	0	0	1	1	display start line (0~63)						Indicates the display data RAM displayed at the top of the screen.
3. Set page (X address)	0	0	1	0	1	1	1	page (0~7)			Sets the page (X address) of RAM at the page (X address) register.
4. Set address	0	0	0	1	Y address (0~63)						Sets the Y address at the Y address counter.
5. Status Read	1	0	B U S Y	0	ON/ OFF	R E S E T	0	0	0	0	Reads the status. RESET 1:Reset, 0:normal. ON/OFF 1: Display OFF, 0: Display ON. BUSY 1: In operation. 0: Ready
6. Write Display Data	0	1	Write Data								Writes data (DB0~7) into display data RAM. After writing instruction, Y address is increased by 1 automatically.
7. Read Display Data	1	1	Read Data								Reads data (DB0~7) from display data RAM to the data bus.

11. Description Of Instructions

(1) Display ON/OFF

	R/W	D/I	DB7	DB6	DB5	DB4	DB3	DB2	DB1	DB0
Code	0	0	0	0	1	1	1	1	1	D

The display data appears when D is 1 and disappears when D is 0. Though the data is not on the screen width D=0, it remains in the display data RAM. Therefore, you can make it appear by changing D=0 or D=1.

(2) Display start line

	R/W	D/I	DB7	DB6	DB5	DB4	DB3	DB2	DB1	DB0
Code	0	0	1	1	A	A	A	A	A	A

Z address AAAAAA (binary) of the display data RAM is set at the display start line register and displayed at the top of the screen.

(3) Set page (X address)

	R/W	D/I	DB7	DB6	DB5	DB4	DB3	DB2	DB1	DB0
Code	0	0	1	0	1	1	1	A	A	A

X address AAA (binary) of the display data RAM is set at the X address register. After that, writing or from MPU is executed in this specified page until the next page is set.

(4) Set Y address

	R/W	D/I	DB7	DB6	DB5	DB4	DB3	DB2	DB1	DB0
Code	0	0	0	1	A	A	A	A	A	A

Y address AAAAAA (binary) of the display RAM is set at the Y address counter is increase by every time data is written or read to or from MPU.

DB0		
I DB7	PAGE 0	X=0
DB0 I DB7	PAGE 1	X=1
	I	
DB0 I DB7	PAGE 6	X=6
DB0 I DB7	PAGE 7	X=7

Address Configuration of Display RAM

(5) Status Read

	R/W	D/I	DB7	DB6	DB5	DB4	DB3	DB2	DB1	DB0
Code	1	0	BUSY	0	ON/OFF	RESET	0	0	0	0

BUSY : When BUSY is 1, The LSI is in internal operation. No instructions are accepted while BUSY is 1, so you should make sure that BUSY is 0 before writing the next instruction.

ON/OFF: This bit show the liquid crystal conditions ON condition or OFF condition. When ON/OFF is 1, the display is on OFF condition. When ON/OFF is 0, the display on ON condition.

RESET: RESET=1 shows that the system is being initialized. In this condition, any instructions except Status Read instruction cannot be accepted. RESET=0 shows that initializing has finished and system is in the usual operation.

(6) Write Display Data

	R/W	D/I	DB7	DB6	DB5	DB4	DB3	DB2	DB1	DB0
Code	0	1	D	D	D	D	D	D	D	D

Writes 8-bit data DDDDDDDD (binary) into display data RAM. The Y address is increased by 1 automatically.

(7) Read Display Data

	R/W	D/I	DB7	DB6	DB5	DB4	DB3	DB2	DB1	DB0
Code	1	1	D	D	D	D	D	D	D	D

Reads out 8-bit data DDDDDDDD (binary) from the display data RAM. The Y address is increased by 1 automatically. One dummy read is necessary soon after the address setting.

12. Initializing And Programming

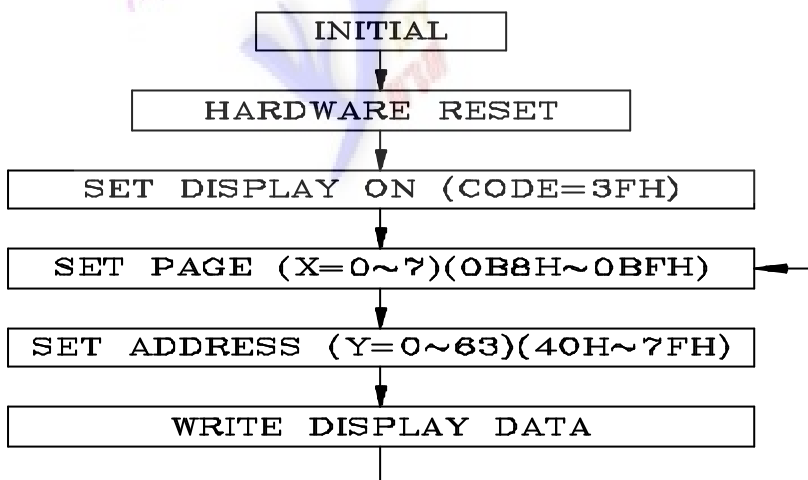

13. Reliability Condition

		TN Type		STN Type		
		Normal Temp.	Wide Temp.	Normal Temp.	Wide Temp.	
Viewing Angle	Horizontal Φ	$\pm 30^\circ$	$\pm 30^\circ$	$\pm 30^\circ$	$\pm 30^\circ$	
	Vertical Θ (mm)	10° to 30°	10° to 30°	-10° to 40°	-10° to 40°	
Operating Temperature		-10 to 70°C	-25 to 80°C	0 to 50°C	*-20 to 70°C	
Storage Temperature		-20 to 80°C	-35 to 90°C	-20 to 70°C	*-30 to 80°C	
High Temperature (Power Off)		240 Hours @70°C	240 Hours @90°C	240 Hours @65°C	240 Hours @75°C	
Low Temperature (Power Off)		240 Hours @-20°C	240 Hours @-35°C	240 Hours @-15°C	240 Hours @-25°C	
High Temperature (Power On)		240 Hours @70°C	240 Hours @80°C	240 Hours @60°C	240 Hours @70°C	
Low Temperature (Power On)		240 Hours @-10°C	240 Hours @-25°C	240 Hours @-10°C	240 Hours @-20°C	
High Temperature & High Humidity		55°C/90%RH 240 Hours	75°C/90%RH 240 Hours	45°C/90%RH 240 Hours	65°C/90%RH 240 Hours	
Thermal Shock 5 Cycle		A	60min@-20°C	60min@-35°C	60min@-20°C	60min@-30°C
		B	5min@25°C	5min@25°C	5min@25°C	5min@25°C
		C	60min@70°C	60min@90°C	60min@70°C	60min@80°C
Expected Lift		50,000 Hours	50,000 Hours	50,000 Hours	50,000 Hours	

*Wide temp. version may not available for some products, Please consult our sales engineer or representative.

14. Functional Test & Inspection Criteria

14.1 Sample plan

Sample plan according to MIL-STD-105D level 2, and acceptance/rejection criteria is.

Base on : Major defect : AQL 0.65 Minor defect : AQL 2.5

14.2 Inspection condition

Viewing distance for cosmetic inspection is 30cm with bare eyes, and under an environment of 800 lus (20W) light intensity. All direction for inspecting the sample should be within 45° against perpendicular line.

14.3 Definition of Inspection Zone in LCD

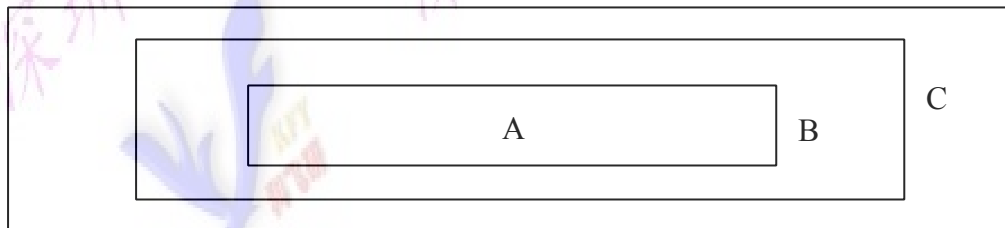

Zone A : Character / Digit area

Zone B : Viewing area except Zone A (Zone A + Zone B = minimum Viewing area)

Zone C : Outside viewing area (invisible area after assembly in customer's product)

Note : As a general rule, visual defects in Zone C are permissible, when it is no trouble for quality and assembly of customer's product.

14.4 Major Defect

All functional defects such as open (or missing segment), short, contrast differential, excess power consumption, smearing, leakage, etc. and overall outline dimension beyond the drawing. Are classified as major defects.

14.5 Minor Defect

Except the Major defects above, all cosmetic defects are classified as minor defects.

Item No.	Item to be Inspected	Inspection Standard				Classification of defects	
1.	Spot defect (Defects in spot from)	Zone size (mm)	Acceptable Qty			Minor	
			A	B	C		
		$\Phi \leq 0.15$	Acceptable (clutering of spot not allowed)		Acceptable		
		$0.15 \leq \Phi \leq 0.20$	1	2			
		$0.20 \leq \Phi \leq 0.25$	0	1			
		$\Phi > 0.25$	0	0			
Remarks : for dark/white spot, size Φ is defined as $\Phi = 1/2(X+Y)$							
2.	Line defect (Defects in line form)	Size (mm)		Acceptable Qty		Minor	
		L Length	W Width	Zone			
				A	B		C
		Acceptable	$W \leq 0.02$	Acceptable	Acceptable		
		$L \leq 3.0$	$W \leq 0.03$	2			
		$L > 2.5$	$W \leq 0.03$	0			
		$L \leq 3.0$	$0.03 < W \leq 0.05$	2			
		$L > 2.5$	$0.03 < W \leq 0.05$	0			
	$W > 0.05$	Counted as spot defect (Follows item 14.5.1)					
Remarks: The total of spot defect and line defect shall not exceed four.							
3.	Orientation defect (such as misalignment of L/C)	Not allowed inside viewing area (Zone A or Zone B)				Minor	
4.	Polarizing	14.5.4.1 Polarizer Position				Minor	
		1. Shifting in Position Should not exceed the glass outline dimension.					
		2. Incomplete covering of the viewing area due to Shifting is not allowed.					
		14.5.4.2 Seratches, bubble or dent on Glass/ Polarizer/Reflector, Bubble between Polarizer & Reflector/Glass:					
		Size (mm)	Acceptable Qty				
			Zone				
			A	B	C		
		$\Phi \leq 0.20$	Acceptable		Acceptable		
$0.20 < \Phi \leq 0.50$	3						
$0.50 < \Phi \leq 1.00$	2						
$\Phi > 1.00$	0						